

# Portable Compressors **MOBILAIR M 200**

With the world-renowned SIGMA PROFILE   
Free air delivery 14.5 to 21.2 m<sup>3</sup>/min



**Made in Germany**

KAESER's renowned MOBILAIR range of portable compressors is manufactured in a state-of-the-art production facility located directly next to the KAESER main plant in Coburg, Northern Bavaria. Equipped with the very latest technology, the recently modernised portable compressor



plant boasts TÜV (German Technical Inspection Agency) certified sound testing facilities for free-field sound level measurement, an advanced powder coating installation and highly efficient production logistics. With minimal turn-around time, KAESER's highly qualified personnel are able to

assemble portable compressors of all sizes and equipment levels to suit our customers' specific needs.

**Maximum versatility**

The Mobilair M 200 is in a class of its own when it comes to versatility, as it can be specifically tailored to meet the needs of the relevant application.

Options include air treatment components, a choice of a fully galvanised chassis with overrun brake and a fixed or height adjustable tow bar, or stationary versions either mounted on skids or machine mountings.

**A look under the enclosure**

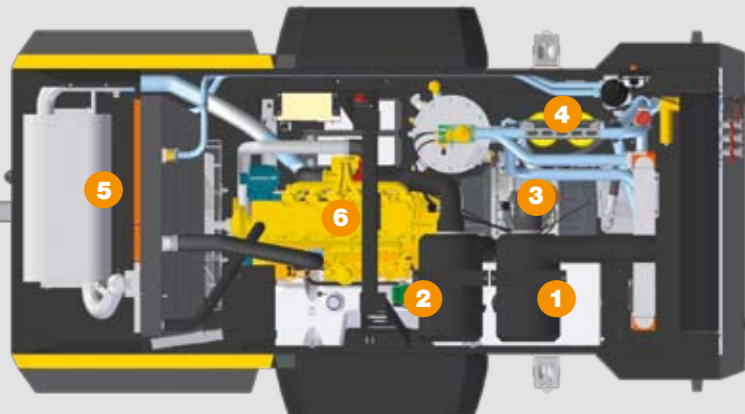

# MOBILAIR M 200 – Power and efficiency



**Simple and convenient pressure adjustment**

Using the arrow keys, system pressure can be precisely adjusted in 0.1 bar increments on the SIGMA CONTROL mobile's display. This not only enhances flexibility but, in combination with the electronic inlet valve control, also achieves significant energy savings – especially when operating in partial load.



**Dedicated intake filter for motor and airend**

Optimised design and separate air filters considerably enhance reliability and service life. The filters can be changed onsite quickly and simply as required.



**Easy to transport**

The M 200 features a fully galvanised Alko chassis as standard. This not only ensures long-term value retention, but also makes transportation simple – a truck is not required to tow the unit.



**The perfect energy-saving combination: Caterpillar engines and KAESER airends**

The powerful combination of an energy-saving Caterpillar engine and the highly efficient KAESER SIGMA Profile rotary screw airend combines outstanding performance with considerably reduced fuel consumption. The MOBILAIR M 200 can operate at full power for a whole shift without refuelling. The water-cooled Caterpillar engine complies with exhaust emission regulations and is certified to EU directive 2004/26 (Tier III A) and USA-EPA (TIER III). Furthermore, users not

only benefit from the quality of two world-class products, but can also rely on the comprehensive KAESER and Caterpillar global service networks to ensure maximum machine availability.

- 1 Compressor air filter
- 2 Engine air filter
- 3 SIGMA airend
- 4 Compressed air treatment (Optional)
- 5 Vertical exhaust outlet with protective cover
- 6 Diesel engine

# MOBILAIR M 200 — Perfect performance even in extreme conditions



## Excellent accessibility

The M 200's user-friendly design not only ensures simple operation and outstanding manoeuvrability: The unit's large gull-wing doors also provide excellent component accessibility for unrivalled ease of maintenance.



## Ambient temperature

Standard models can be used in ambient temperatures ranging from -10 °C to +50 °C, whilst the low temperature versions can be used in temperatures as low as -25 °C.



## Large capacity, transparent fuel tank

When fully filled, the tank carries sufficient fuel for an entire work shift without the need for refuelling. For ease of operation, an automatic shut-down feature is activated when the fuel level becomes too low. A pre-warning from the Sigma Control mobile provides additional peace of mind.



## Oil temperature control

The M 170's automatically controlled thermostatic valve ensures that optimal operating temperature is reached quickly and reliably. It therefore protects the compressor's fluid circulation loop from excessive condensate accumulation. This in turn significantly extends cooling fluid and separator cartridge service life and also enhances the unit's long-term durability.



## Cool, clean compressed air

The compressed air is cooled to 7 °C above ambient temperature. Accumulated condensate is able to drain away easily, as the compressed air cooler is installed at an angle, whilst the hot exhaust gasses from the motor are also used to aid condensate evaporation. This design consequently ensures reliable frost protection during the winter months.



## Compressed air treatment

Additional air treatment components need to be installed downstream from the aftercooler and centrifugal separator (e.g. filter combinations for concrete cleaning as per ZTV-SIB) in order to achieve compressed air of a specified quality class. The differential pressure indicator enables filter status to be monitored quickly and easily.



## User-friendly operation

The ability to switch over manually from idling to full load operation ensures a reliable, gentle start when operating the unit in cold ambient conditions.

The Sigma Control mobile and intuitive operation mean that only 3 buttons are required to operate the M 170. Features also include automatic monitoring and shutdown and an optional cover flap to protect the control panel.

## SIGMA CONTROL mobile

This advanced compressor controller ensures optimised compressed air availability and fuel efficiency using state-of-the-art electronic motor management. The system is both shock- and vibration proof and provides electric protection in accordance with IP 55 standards. Features include user-friendly operation, system monitoring and diagnostics.





## Air treatment systems

<p><b>System A</b></p> <ul style="list-style-type: none"> <li>• Cool</li> <li>• Condensate-free</li> </ul>		<p>Cool, condensate-free compressed air (100% saturated), <b>for driving air tools and temporarily replacing stationary compressors</b></p>
<p><b>System F</b></p> <ul style="list-style-type: none"> <li>• Cool</li> <li>• Condensate-free</li> <li>• Filtered</li> </ul>		<p>Cool, condensate-free compressed air (100% saturated), <b>free from dirt particles and oil in accordance with applicable regulations</b></p>
<p><b>System B</b></p> <ul style="list-style-type: none"> <li>• Warmed</li> <li>• Dried</li> </ul>		<p>Dried compressed air, warmed to approx. 20 °C, <b>for working at sub-zero temperatures and with long air lines</b></p>
<p><b>System G</b></p> <ul style="list-style-type: none"> <li>• Warmed</li> <li>• Dried</li> <li>• Filtered</li> </ul>		<p>Dried compressed air, warmed to at least 20 °C, <b>free from dirt particles and oil in accordance with applicable regulations</b></p>
<p><b>Fresh air</b></p> <p>As partial flow</p>	<p>Does not provide protection from carbon monoxide or other noxious gases.</p>	<p>Odour-free fresh air connected via a <b>separate</b> quick-release coupling (Only in combination with one of the above mentioned air treatment systems)</p>

Additional air treatment systems for the MOBILAIR M 200 are available upon request. Please contact Kaeser for further details.

## Dimensions

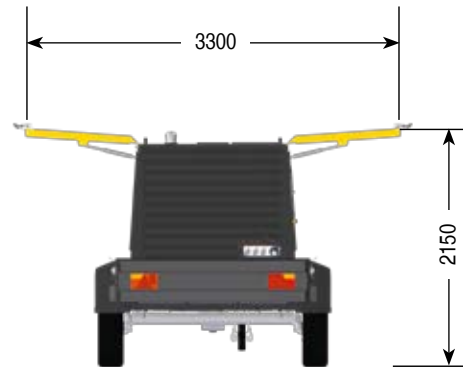
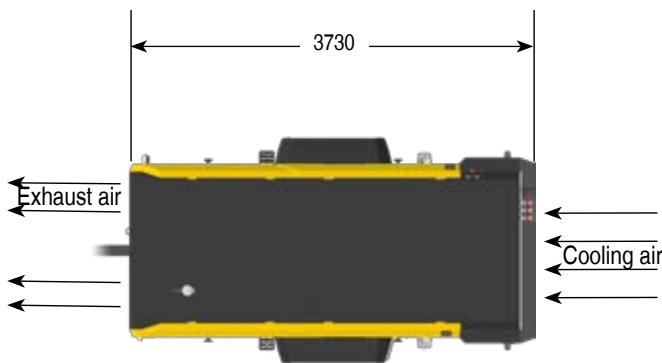
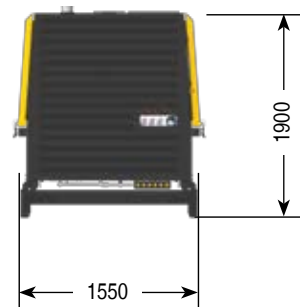
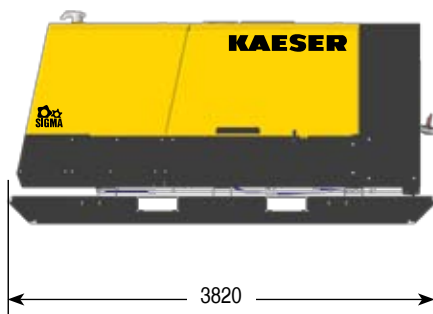
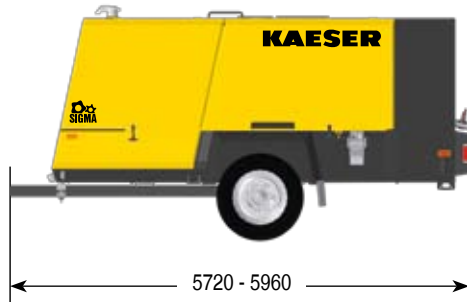

## Technical Specifications: MOBILAIR M 200

Model	Compressor unit		6-cylinder diesel engine (Water-cooled)					Complete unit				
	Air delivery m <sup>3</sup> /min	Working pressure bar	Make	Model	Rated motor power kW	Speed at full load rpm	Idling speed rpm	Fuel tank capacity l	Operational weight kg	Sound power level dB(A)*	Sound pressure level dB(A)**	Air connection
M 200	21.2	7	Caterpillar	C 6.6 ACERT	146	1950	1200	270	3235	Only for export outside of the EU		3 x G <sup>3</sup> / <sub>4</sub> 1 x G2
	19.7	8.6				1800	1200			≤99	70	
	18.0	10										
	16.0	12										
	14.5	14										

\*) Guaranteed sound power level to directive 2000/14/EU – Stage 2    \*\*) Surface sound pressure level to ISO 3744, (r = 10 m)

# KAESER – The world is our home

As one of the world's largest manufacturers of rotary screw compressors, KAESER KOMPRESSOREN is represented throughout the world by a comprehensive network of branches, subsidiary companies and authorised partners in over 60 countries.

With innovative products and services, Kaeser Kompressoren's experienced consultants and engineers help customers to enhance their competitive edge by working in close partnership to develop progressive system concepts that continuously push the boundaries of performance and compressed air efficiency. Moreover, the decades of knowledge and expertise from this industry-leading system provider are made available to each and every customer via the Kaeser group's global computer network.

These advantages, coupled with KAESER's worldwide service organisation, ensure that all products operate at the peak of their performance at all times and provide maximum availability.



## **KAESER Compressors SA (PTY) Ltd.**

79 Watt Street – 1401 Meadowdale-Johannesburg – P.O. Box 5031  
Phone: 0027 11974 5002 – Fax: 0027 11974 6696  
[www.kaeser.co.za](http://www.kaeser.co.za) – Email: [info.southafrica@kaeser.com](mailto:info.southafrica@kaeser.com)



## **KAESER Kompressoren GmbH**

P.O. Box 2143 – 96410 Coburg – GERMANY – Tel: +49 9561 640-0 – Fax: +49 9561 640130  
[www.kaeser.com](http://www.kaeser.com) – e-mail: [productinfo@kaeser.com](mailto:productinfo@kaeser.com)

