

Portable Compressors **MOBILAIR M 135**

With the world-renowned SIGMA PROFILE 
Free air delivery 10.5 to 13.0 m³/min



Made in Germany

KAESER's renowned MOBILAIR range of portable compressors is manufactured in a state-of-the-art production facility located directly next to the KAESER main plant in Coburg, Northern Bavaria. Equipped with the very latest technology, the recently modernised portable



compressor plant boasts TÜV (German Technical Inspection Agency) certified sound testing facilities for free-field sound level measurement, an advanced powder coating installation and highly efficient production logistics. With minimal turn-around time, KAESER's highly qualified

personnel are able to assemble portable compressors of all sizes and equipment levels to suit our customers' specific needs.

Maximum versatility

The MOBILAIR M 135 is in a class of its own when it comes to versatility, as it can be specifically tailored to meet the needs of the relevant application.

Options include air treatment components, a choice of a fully galvanised chassis with overrun brake and a fixed or height adjustable tow bar, or stationary versions either mounted on skids or machine mountings.

Moreover, the M 135 can be equipped with a 15 kVA or a 23 kVA generator that communicates with the unit's control system. This flexible control technology ensures maximum availability of compressed air and electrical energy at all times.

A look under the enclosure

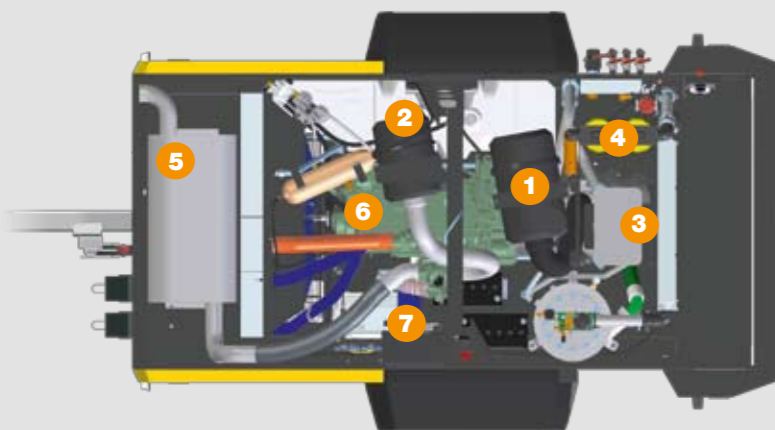

**MOBILAIR M 135 –
Power and efficiency**



- 1 Compressor air filter
- 2 Engine air filter
- 3 SIGMA airend
- 4 Compressed air treatment (Optional)
- 5 Internal exhaust silencer (protected from potential damage)
- 6 Diesel engine
- 7 Generator (Optional)



Simple and convenient pressure adjustment

Using the arrow keys, system pressure can be precisely adjusted in 0.1 bar increments on the SIGMA CONTROL mobile's display. This not only enhances flexibility but, in combination with the electronic inlet valve control, also achieves significant energy savings – especially when operating in partial load.



Ambient temperature

Standard models can be used in ambient temperatures ranging from -10 °C to +50 °C, whilst the low temperature versions can be used in temperatures as low as -25 °C.



Easy to transport

The M 135 features a fully galvanised Alko chassis as standard. This not only ensures long-term value retention, but also makes transportation simple – a truck is not required to tow the unit.



**The perfect energy-saving combination:
Deutz engines and KAESER airends**

The powerful combination of an energy-saving Deutz engine and the highly efficient KAESER SIGMA Profile rotary screw airend combines outstanding performance with considerably reduced fuel consumption. The MOBILAIR M 135 can operate at full power for a whole shift without refuelling. The water-cooled Deutz engine complies with exhaust emission regulations and is certified to EU directive 2004/26 (Tier III A) and USA-EPA (TIER III).

Furthermore, users not only benefit from the quality of two world-class products, but can also rely on the comprehensive KAESER and Deutz global service networks to ensure maximum machine availability.

MOBILAIR M 135 — Perfect performance even in extreme conditions



Excellent accessibility

The M 135's user-friendly design not only ensures simple operation and outstanding manoeuvrability: The unit's large gull-wing doors also provide excellent component accessibility for unrivalled ease of maintenance.



Large capacity, transparent fuel tank

When fully filled, the tank carries sufficient fuel for an entire work shift without the need for refuelling. For ease of operation, an automatic shut-down feature is activated when the fuel level becomes too low. A pre-warning from the Sigma Control mobile provides additional peace of mind.



Oil temperature control

The M 135's automatically controlled thermostatic valve ensures that optimal operating temperature is reached quickly and reliably. It therefore protects the compressor's fluid circulation loop from excessive condensate accumulation. This in turn significantly extends cooling fluid and separator cartridge service life and also enhances the unit's long-term durability.



Cool, clean compressed air

The compressed air is cooled to 7°C above ambient temperature. Accumulated condensate is able to drain away easily, as the compressed air cooler is installed at an angle, whilst the hot exhaust gasses from the motor are also used to aid condensate evaporation. This design consequently ensures reliable frost prevention during the winter months.

Additional air treatment components need to be installed downstream from the after-cooler and centrifugal separator (e.g. filter combinations for concrete cleaning as per ZTV-SIB) in order to achieve compressed air of a specified quality class (see next page). The differential pressure indicator enables filter status to be monitored quickly and easily.



Generator

An optional 15 or 23 kVA synchronous three-phase (IP54) generator is also available. The brushless unit is maintenance-free and delivers frequency and voltage data to the compressor control system. This consequently ensures maximum reliability and best possible compressed air delivery volumes even at times of high energy demand.

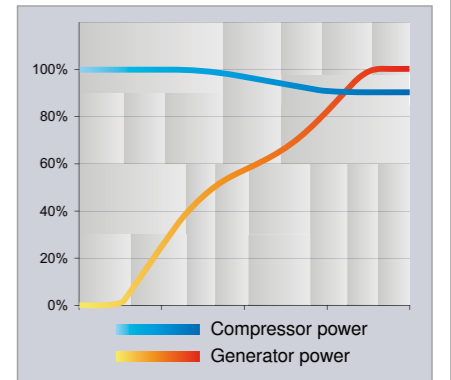

Generator version:

The switch panel - which can be equipped with a cover flap if required - features splash-protected sockets in accordance with IP 44 and a lockable main switch. The safety cut-out system with insulation monitoring makes earthing superfluous. A convenient switch enables simple changeover from continuous operation to energy-saving automatic start mode. Efficiency is further enhanced by the compressor's intelligent control system.



User-friendly operation

The ability to switch over manually from idling to full load operation ensures a reliable, gentle start when operating the unit in cold ambient conditions.

The Sigma Control mobile and intuitive operation mean that only 3 buttons are required to operate the M 135. Features also include automatic monitoring and shutdown and an optional cover flap to protect the control panel.

SIGMA CONTROL mobile

This advanced compressor controller ensures optimised compressed air availability and fuel efficiency using state-of-the-art electronic motor management. The system is both shock- and vibration proof and provides electric protection in accordance with IP 55 standards. Features include user-friendly operation, system monitoring and diagnostics.





Air treatment systems

<p>System A</p> <ul style="list-style-type: none"> • Cool • Condensate-free 		<p>Cool, condensate-free compressed air (100 % saturated), for driving air tools and temporarily replacing stationary compressors</p>
<p>System F</p> <ul style="list-style-type: none"> • Cool • Condensate-free • Filtered 		<p>Cool, condensate-free compressed air (100 % saturated), free from dirt particles and oil in accordance with applicable regulations</p>
<p>System B</p> <ul style="list-style-type: none"> • Warmed • Dried 		<p>Dried compressed air, warmed to approx. 20 °C, for working at sub-zero temperatures and with long air lines</p>
<p>System G</p> <ul style="list-style-type: none"> • Warmed • Dried • Filtered 		<p>Dried compressed air, warmed to at least 20 °C, free from dirt particles and oil in accordance with applicable regulations</p>
<p>Fresh air as partial flow</p>	<p>Does not provide protection from carbon monoxide (CO) or other noxious gases.</p>	<p>Odour-free fresh air connected via a separate quick-release coupling (only in combination with one of the above mentioned air treatment systems)</p>

Additional air treatment systems for the MOBILAIR M 135 are available upon request. Please contact Kaeser for further details.

Dimensions

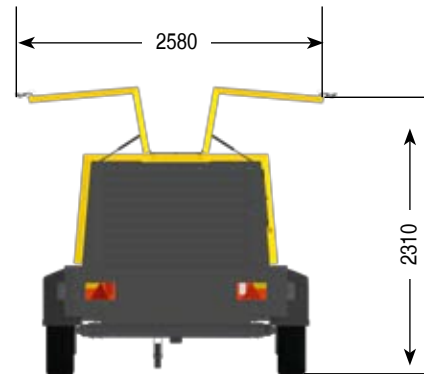
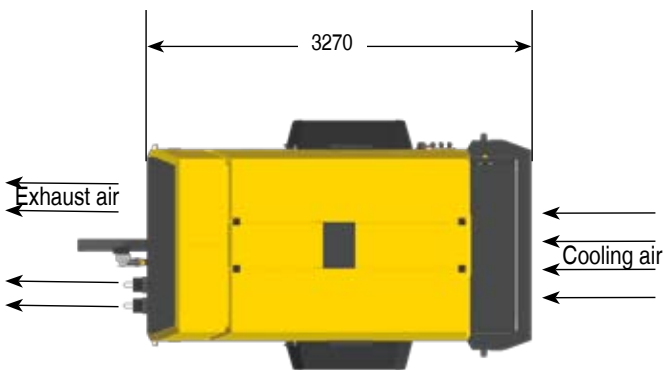
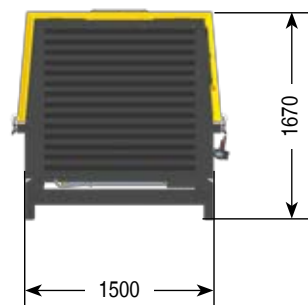
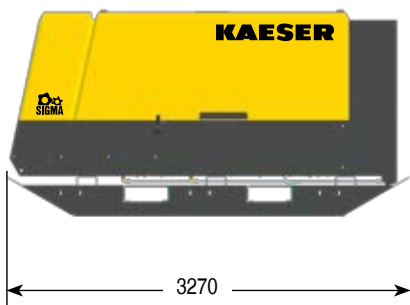
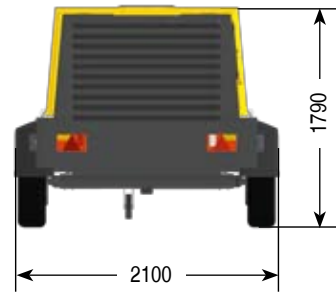

Technical Specifications: MOBILAIR M 135

Model	Compressor		4-cylinder diesel engine (Water-cooled)					Complete unit				
	FAD m ³ /min	Working pressure bar	Make	Model	Rated motor power kW	Speed at full load rpm	Idling speed rpm	Fuel tank capacity l	Operational weight kg	Sound power level dB(A)*	Sound pressure level dB(A)**	Air connection
M135	13.0 12.0 10.5	10 12 14	Deutz	TCD 2013 L04	122	2000	1300	200	2500	≤99	70	3 x G ³ / ₄ 1 x G ₂

*) Guaranteed sound power level to directive 2000/14/EU – Stage 2, guaranteed sound power level – **) Surface sound pressure level to ISO 3744, (r = 10 m)

KAESER – The world is our home

As one of the world's largest manufacturers of rotary screw compressors, KAESER KOMPRESSOREN is represented throughout the world by a comprehensive network of branches, subsidiary companies and authorised partners in over 60 countries.

With innovative products and services, Kaeser Kompressoren's experienced consultants and engineers help customers to enhance their competitive edge by working in close partnership to develop progressive system concepts that continuously push the boundaries of performance and compressed air efficiency. Moreover, the decades of knowledge and expertise from this industry-leading system provider are made available to each and every customer via the Kaeser group's global computer network.

These advantages, coupled with KAESER's worldwide service organisation, ensure that all products operate at the peak of their performance at all times and provide maximum availability.



KAESER Compressors SA (PTY) Ltd.

79 Watt Street – 1401 Meadowdale-Johannesburg – P.O. Box 5031
Phone: 0027 11974 5002 – Fax: 0027 11974 6696
www.kaeser.co.za – Email: info.southafrica@kaeser.com



KAESER Kompressoren GmbH

P.O. Box 2143 – 96410 Coburg – GERMANY – Tel: +49 9561 640-0 – Fax: +49 9561 640130
www.kaeser.com – e-mail: productinfo@kaeser.com

