

## Portable Compressors **MOBILAIR M 122**

With the world-renowned SIGMA PROFILE 

Free air delivery 11.1 m<sup>3</sup>/min



**Worldwide sales and service network**

KAESER is one of the world's foremost compressor manufacturers and providers of compressed air systems – its products are renowned for their outstanding quality, advanced technology and exceptional efficiency.

Represented in every major industrial nation throughout the world by a

comprehensive network of international offices and authorised partners KAESER KOMPRESSOREN is dedicated to ensuring unrivalled equipment availability and fast, reliable customer service.



# MOBILAIR M 122 – Superior Power and Flexibility

**Maximum versatility**

The Mobilair M 122 is in a class of its own when it comes to versatility, as it can be specifically tailored to meet the needs of the relevant application.

Options include air treatment components, a choice of a fully galvanised chassis with overrun brake and a fixed or height adjustable tow bar, or stationary versions either mounted on skids or machine mountings.



**Proportional controller with manual wheel control\*)**

For added flexibility, a manual wheel control on the proportional controller enables infinitely variable pressure adjustment.

\*) Available for 10 to 14 bar versions.



**Dedicated intake filter for motor and airend**

Optimised design and separate air filters considerably enhance reliability and service life. The filters can be changed onsite quickly and simply as required.



**Easy to transport**

The M 122 features a fully galvanised Alko chassis as standard. This not only ensures long-term value retention, but also makes transportation simple – a truck is not required to tow the unit.

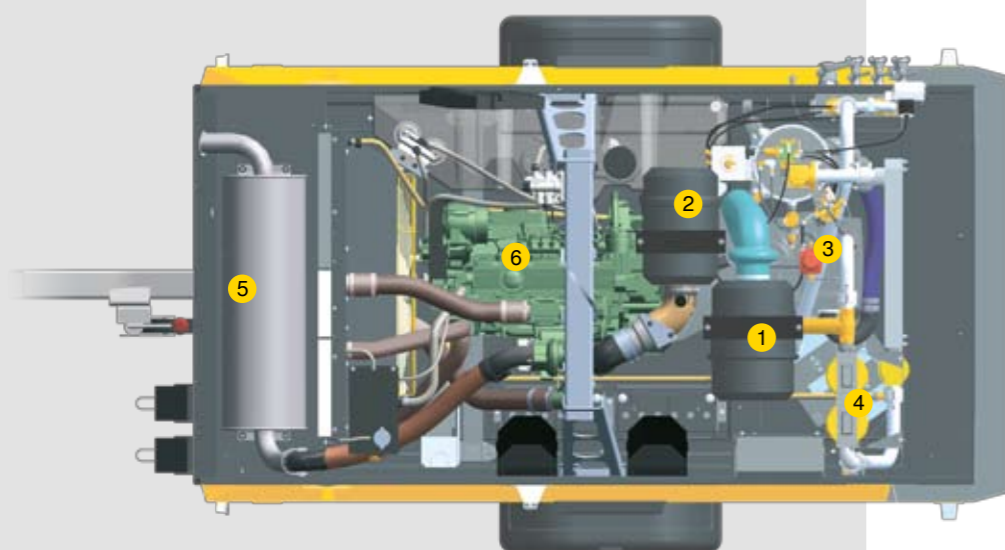

- 1 Compressor air filter
- 2 Engine air filter
- 3 SIGMA airend
- 4 Compressed air treatment (Option)
- 5 Internal exhaust silencer (protected from potential damage)
- 6 Diesel engine



**The perfect energy-saving combination: Deutz engines and KAESER airends**

The powerful combination of an energy-saving Deutz engine and a highly efficient KAESER SIGMA PROFILE airend provides outstanding performance with minimal fuel consumption. The MOBILAIR M 122 can operate at full power for a whole shift without refuelling. The water-cooled Deutz engine complies with exhaust emission regulations and is certified to EU directive 2004/26 (Tier III A) and USA-EPA (TIER III). Furthermore, users

not only benefit from the quality of two world-class products, but can also rely on the comprehensive KAESER and Deutz global service networks to ensure maximum machine availability.

# MOBILAIR M 122 — Perfect Performance even in Extreme Conditions



## Large capacity, transparent fuel tank

When fully filled, the tank carries sufficient fuel for an entire work shift without the need for refuelling. For ease of operation, an automatic shut-down feature is activated when the fuel level becomes too low.



## Tool storage space

The integrated tool box provides generous storage space for all tools and accessories. A second tool box is also optionally available.

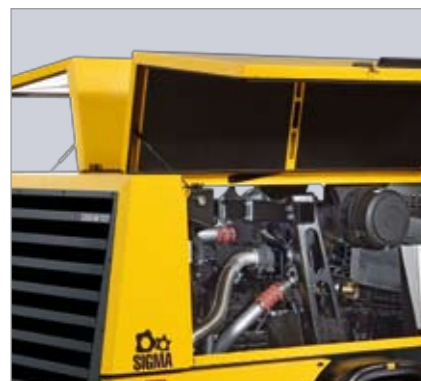

## Large gull-wing doors

The M 122's user-friendly design not only ensures simple operation and outstanding manoeuvrability: The unit's large gull-wing doors also provide excellent component accessibility for unrivalled ease of maintenance.



## Thermostatic valve for oil temperature regulation

The M 122's automatically controlled thermostatic valve ensures that optimal operating temperature is reached quickly and reliably. It therefore protects the compressor's fluid circulation loop from excessive condensate accumulation. This in turn significantly extends cooling fluid and separator cartridge service life and also enhances the unit's long-term durability.



## User-friendly operation

The user-friendly control and instrument panel enables all information to be viewed at a glance. Features also include automatic monitoring and shutdown.

The combination of the pre-heat function start switch and the ability to switch over manually from idling to full load operation ensures a reliable, gentle start when operating the unit in cold ambient conditions.



## Cool, clean compressed air

The compressed air is cooled to 7 °C above ambient temperature.

Accumulated condensate is able to drain away easily, as the compressed air cooler is installed at an angle, whilst the hot exhaust gasses from the motor are also used to aid condensate evaporation. This design consequently ensures reliable frost protection during the winter months.



## Filter combination

Additional air treatment components need to be installed downstream from the after-cooler and centrifugal separator (e.g. filter combinations for concrete cleaning as per ZTV-SIB) in order to achieve compressed air of a specified quality class. The differential pressure indicator enables filter status to be monitored quickly and easily.





## Ambient temperature

Standard models can be used in ambient temperatures ranging from -10 °C to +50 °C, whilst the low temperature versions can be used in temperatures as low as -25 °C.

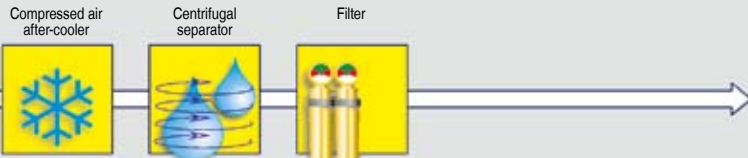
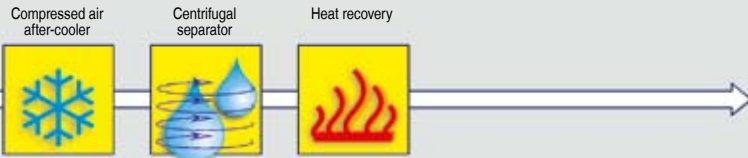
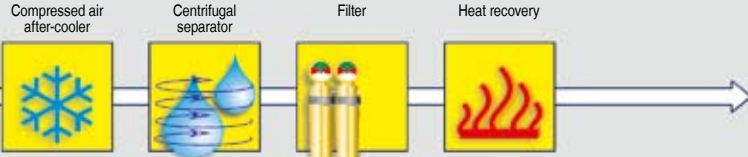

# Air treatment systems

|   |  |   |
|---|--|---|
| <p><b>System A</b></p> <ul style="list-style-type: none"> <li>• Cool</li> <li>• Condensate-free</li> </ul>                      |    | <p>Cool, condensate-free compressed air (100 % saturated), <b>for powering air tools and temporarily replacing stationary compressors</b></p>           |
| <p><b>System F*</b></p> <ul style="list-style-type: none"> <li>• Cool</li> <li>• Condensate-free</li> <li>• Filtered</li> </ul> |    | <p>Cool, condensate-free compressed air (100 % saturated), <b>free from dirt particles and oil in accordance with applicable regulations</b></p>        |
| <p><b>System B</b></p> <ul style="list-style-type: none"> <li>• Warmed</li> <li>• Dried</li> </ul>                              |    | <p>Dried compressed air, warmed to at least 20 °C, <b>for working at subzero temperatures and with long air lines</b></p>                               |
| <p><b>System G*</b></p> <ul style="list-style-type: none"> <li>• Warmed</li> <li>• Dried</li> <li>• Filtered</li> </ul>         |   | <p>Dried compressed air, warmed to at least 20 °C, <b>free from dirt particles and oil in accordance with applicable regulations</b></p>                |
| <p><b>Breathing-quality air</b></p> <p>Additional filtration to provide partial flow as breathing air</p>                       |  | <p>Breathing air connected via a <b>separate</b> quick-release coupling (Only in combination with one of the above mentioned air treatment systems)</p> |

Additional air treatment systems for the MOBILAIR M 122 are available on request. Please contact Kaeser for further details.

\* From 8.6 bar

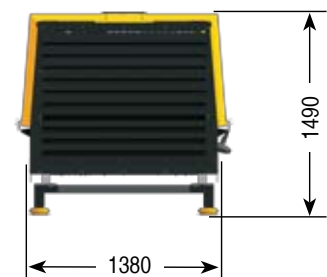
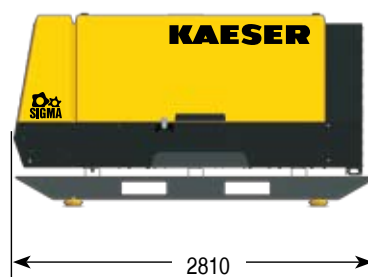
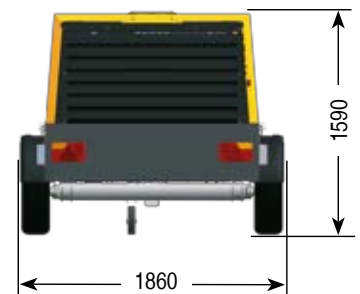



## Technical Specifications: MOBILAIR M 122

| Model        | Compressor unit                          |                         | 4-cylinder diesel engine<br>(Water-cooled) |           |                         |                           |                     | Complete unit           |                          |                             |                                 |   |
|--------------|--|-------------------------|--|-----------|-------------------------|---------------------------|---------------------|-------------------------|--------------------------|-----------------------------|---------------------------------|---|
|              | Free air delivery<br>m <sup>3</sup> /min | Working pressure<br>bar | Make                                       | Model     | Rated motor power<br>kW | Speed at full load<br>rpm | Idling speed<br>rpm | Fuel tank capacity<br>l | Operational weight<br>kg | Sound power level<br>dB(A)* | Sound pressure level<br>dB(A)** | Air connection  |
| <b>M 122</b> | 11.1                                     | 7                       | Deutz                                      | TCD2012L4 | 83                      | 2300                      | 1600                | 170                     | 1865                     | ≤99                         | 70                              | 3 x G <sup>3</sup> / <sub>4</sub><br>1 x G1 <sup>1</sup> / <sub>2</sub> |
|              | 10.1                                     | 8.6                     |  |           |                         |                           |                     |                         |                          |                             |                                 |   |
|              | 9.5                                      | 10                      |  |           |                         |                           |                     |                         |                          |                             |                                 |   |
|              | 8.2                                      | 12                      |  |           |                         |                           |                     |                         |                          |                             |                                 |   |
|              | 7.3                                      | 14                      |  |           |                         |                           |                     |                         |                          |                             |                                 |   |

\*) Guaranteed sound power level to directive 2000/14/EU – Stage 2, \*\*) Surface sound pressure level to ISO 3744, (r = 10 m)

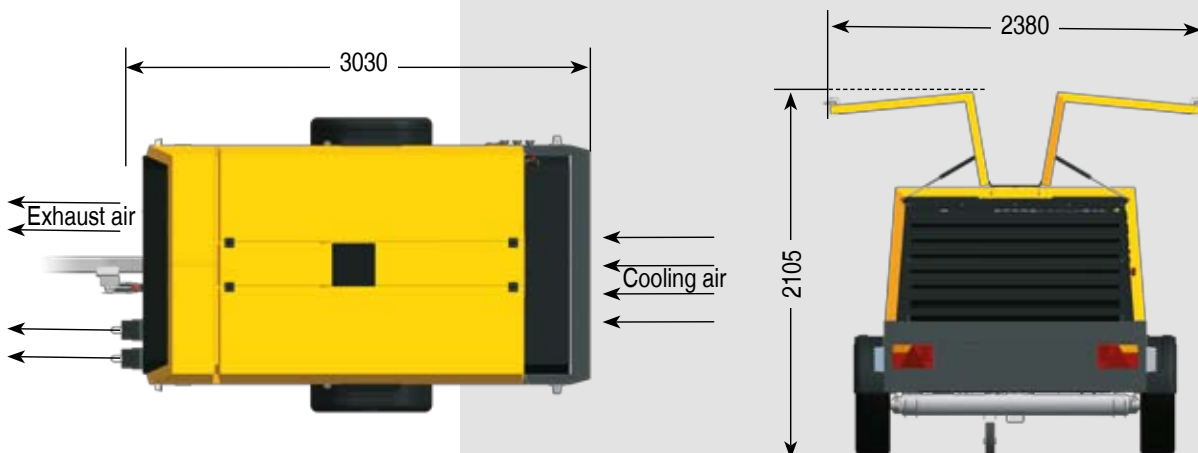



## Worldwide sales and service network: KAESER – Always there

With over 3500 employees worldwide, Kaeser is one of the world's foremost compressor manufacturers and providers of compressed air systems. Kaeser is represented in every major industrial nation throughout the world by 38 subsidiary companies and 48 authorised partners.



|            |                |            |            |             |                       |                 |                |
|------------|----------------|------------|------------|-------------|-----------------------|-----------------|----------------|
| Algeria    | Columbia       | Greece     | Korea      |             |                       |                 |                |
| Argentina  | Costa Rica     | Guatemala  | Latvia     |             |                       |                 |                |
| Australia  | Croatia        | Honduras   | Lithuania  |             |                       |                 |                |
| Austria    | Cyprus         | Hungary    | Luxemburg  |             |                       |                 |                |
| Bangladesh | Czech Republic | Iceland    | Malaysia   |             |                       |                 |                |
| Bahrain    | Denmark        | India      | Mauritania |             |                       |                 |                |
| Belarus    | Ecuador        | Indonesia  | Mauritius  | Peru        | Saudi Arabia          | Spain           | Turkey         |
| Belgium    | Egypt          | Ireland    | Mexico     | Philippines | Sweden                | South Africa    | Ukraine        |
| Brazil     | El Salvador    | Italy      | Morocco    | Poland      | Switzerland           | Sri Lanka       | United Kingdom |
| Bulgaria   | Estonia        | Japan      | Norway     | Portugal    | Serbia and Montenegro | Taiwan          | Uruguay        |
| Canada     | Finland        | Jordan     | Oman       | Qatar       | Singapore             | Thailand        | USA            |
| Chile      | France         | Kazakhstan | Pakistan   | Romania     | Slovakia              | The Netherlands | U.A.E.         |
| China      | Germany        | Kenya      | Panama     | Russia      | Slovenia              | Tunisia         | Vietnam        |

### KAESER Compressors SA (PTY) Ltd.

79 Watt Street – 1401 Meadowdale-Johannesburg – P.O. Box 5031  
 Phone: 0027 11974 5002 – Fax: 0027 11974 6696  
 www.kaeser.co.za – Email: info.southafrica@kaeser.com



### KAESER KOMPRESSOREN GmbH

P.O. Box 2143 – 96410 Coburg – GERMANY – Tel: +49 9561 640-0 – Fax: +49 9561 640130  
 www.kaeser.com – e-mail: productinfo@kaeser.com

