

SECOTEC® Refrigeration Dryers

Air flow rate 0.6 to 25 m³/min



Why is it necessary to dry compressed air?

The atmospheric air drawn into a compressor is a mixture of gases that always contains water vapour.

However, the amount of water vapour that air can carry varies and is mostly dependent on temperature. As air temperature rises – which occurs during compression – the air’s capability to hold moisture increases also.

When the air is cooled its capacity to hold moisture reduces, which causes the water vapour to condense. This condensate is then removed in the centrifugal separator, or in the air receiver, downstream from the compressor. Even then, the air can still be completely saturated with water vapour.

This is why, as the air cools further, significant amounts of condensate can accumulate in the air distribution piping and at take-off points.

System failure, production downtime and costly service and repair work are therefore unavoidable without additional air drying.

Refrigeration dryers usually offer the most efficient solution for the majority of compressed air applications. Compressed air drying is now made even more cost-effective with KAESER’s advanced SECOTEC® systems.

Function diagram

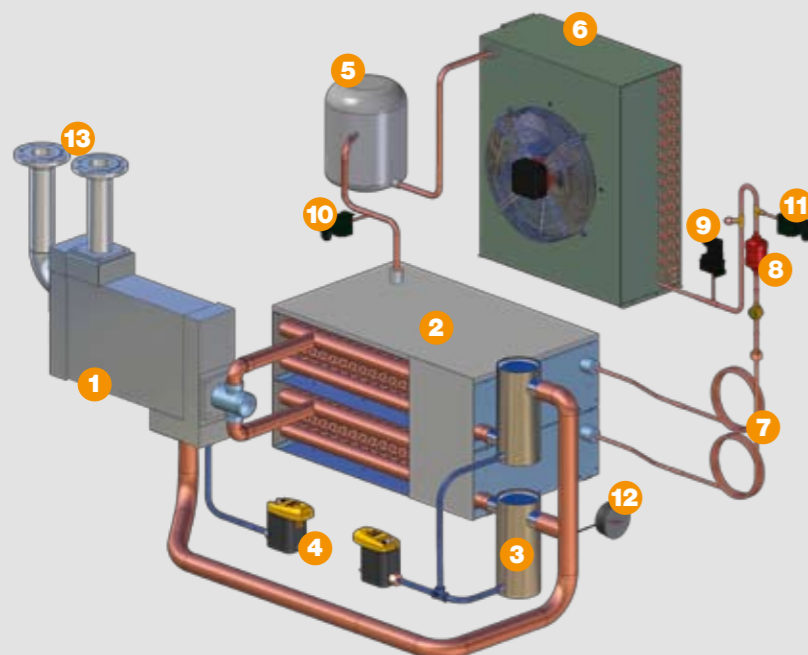

**SECOTEC®
Enhanced energy savings**

The SECOTEC® System

In developing the SECOTEC dryer range, KAESER’s goal was to produce a system that consumed minimal energy and which would provide optimal reliability and user-friendliness.

The resulting SECOTEC system from KAESER KOMPRESSOREN fulfils all of these requirements and, in contrast to most refrigeration drying systems, uses a highly efficient cycling system: SECOTEC Control. Therefore, the dryer’s refrigeration circuit consumes power only when necessary.



- 1 Air / air heat exchanger
- 2 Air / refrigerant heat exchanger with thermal mass
- 3 Condensate separator
- 4 ECO DRAIN
- 5 Refrigerant compressor
- 6 Condenser
- 7 Capillary tubes
- 8 Filter dryer
- 9 High pressure switch
- 10 Low pressure switch
- 11 Fan pressure switch
- 12 PDP indicator
- 13 Compressed air inlet/outlet



Designed and built by KAESER

As one of the world’s foremost compressed air system providers and manufacturers, KAESER ensures that every SECOTEC dryer provides exceptional performance. Each unit is built in accordance with the very highest quality standards at the KAESER Gera plant and undergoes stringent quality inspection as per KAESER’s Quality Management System.

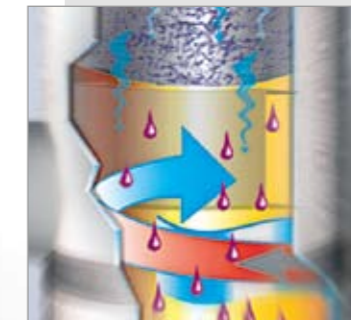

Condensate separator

As with all KAESER products, SECOTEC dryers are designed for maximum reliability. They are equipped with a specially designed condensate separator made from corrosion-resistant stainless steel*) that reliably removes condensate from the air even under fluctuating airflow conditions.

*) TA 5 model uses a zinc die-cast condensate separator



Minimal pressure drop

SECOTEC dryers use flow-optimised piping and usually do not require the use of a pre-filter. Pressure losses are therefore kept to a minimum, which means that maximum system pressure can be significantly reduced. This leads to considerable savings, as each 1 bar reduction represents a 6 % decrease in power consumption and also means less air is lost through leakage.

Air consumption over a 24-hour period

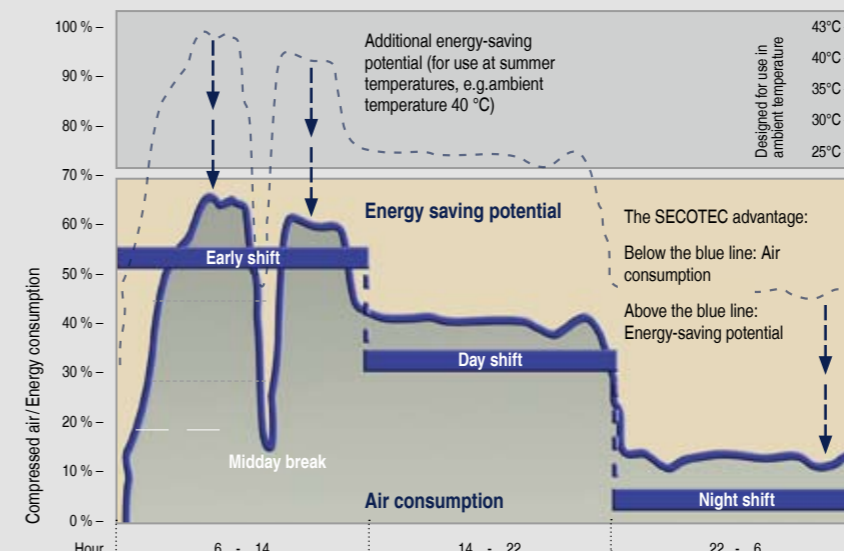

The cost saving effect of the SECOTEC® system

The TB 19 dryer saves a total of approximately € 600 per year compared with dryers which use hot gas by pass control. This cost saving is calculated as follows:

$$(8760 \text{ h} - 1000 \text{ h}) \times 0.43 \text{ kW} \times 0.20 \text{ €/kWh} = \text{€ } 667$$

The graph (left) shows a typical compressed air consumption profile. SECOTEC dryers save energy because the refrigerant system is shut down during breaks, periods of low demand and downtime – the control system operates without preset run-on periods. The integrated thermal mass ensures that the system is ready for operation at all times.

SECOTEC® – Energy savings all day, every day

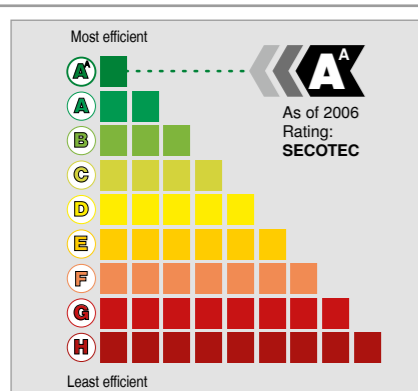

Energy savings all day, every day, with SECOTEC® Control

The high capacity thermal mass is cooled down to cut-out temperature by the refrigeration circuit and extracts the heat from the compressed air that flows through the heat exchanger. As soon as the temperature of the thermal mass rises to the cut-in temperature the refrigerant compressor starts and cools it down again. This feature considerably enhances efficiency compared with non-cycling controllers.

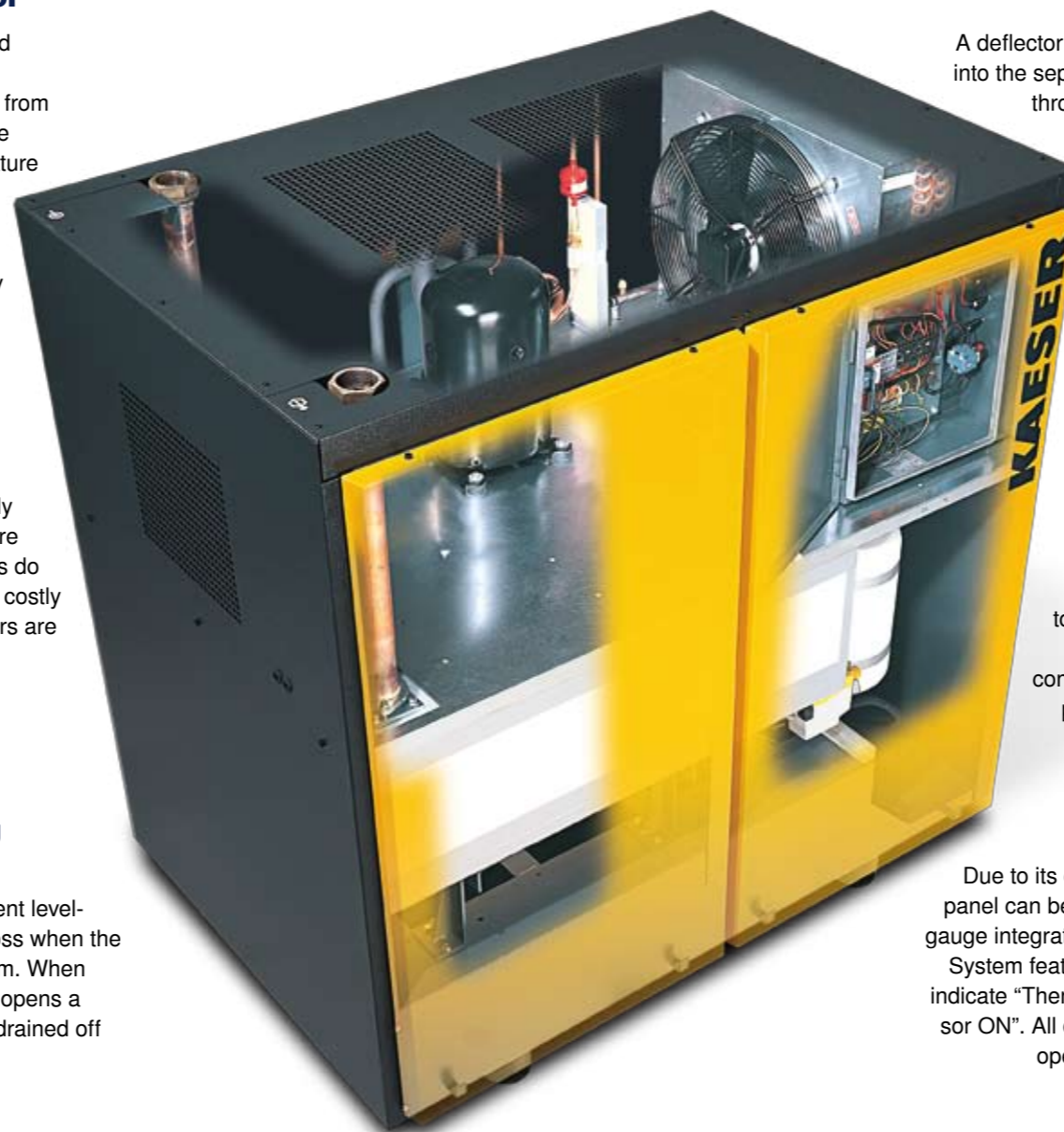

Minimal pressure drop for greater energy savings

The air/air and refrigerant/air heat exchangers are equipped with generously sized smooth-flow copper piping to ensure minimal pressure drop. SECOTEC dryers do not require a pre-filter, which means that costly pressure drops caused by additional filters are avoided.



Dependable, energy saving condensate drainage

The ECO-DRAIN is fitted with an intelligent level-sensing control that prevents pressure loss when the condensate is drained from the air system. When the collector tank is full, the level sensor opens a diaphragm valve and the condensate is drained off without pressure loss.



Simple, cost-effective servicing

All components in SECOTEC dryers are easily accessible when the unit's panels are removed. Service valves are also provided to make inspection of the refrigerant circuit as simple as possible. Furthermore, the condenser is located at the front of the dryer, which allows possible dirt accumulation to be quickly spotted and rectified. Logical component layout and the tower design not only enable maintenance work to be carried out easily, but also significantly reduce servicing requirement and therefore costs.



Efficient stainless steel condensate separator

A deflector plate forces the compressed air that streams into the separator into circular motion. The air then flows through a stainless steel wire mesh that ensures 99.9 % water separation from the air. This allows the required pressure dew point of +3 °C to be reliably maintained. The stainless steel separator tank*) is completely corrosion resistant.

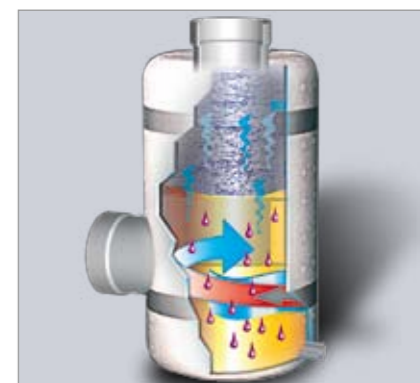

Industrial quality control cabinet for increased safety

Every SECOTEC dryer is EN 60204-1 compliant and is tested for electromagnetic compatibility in accordance with applicable EMC standards. Unlike equipment conforming to VDE 0700, SECOTEC dryers conform to a strict industrial standard and are therefore equipped with a control cabinet to IP 54, a control transformer and fuses for the control and power circuits. The whole system is designed with maximum safety and reliability in mind.



User-friendly operation

Due to its convenient position on all models, the control panel can be viewed at a glance, whilst a dew point trend gauge integrated within the panel monitors dryer operation. System features include: Emergency/Off switch, LEDs to indicate "Thermal Mass Active" and "Refrigerant Compressor ON". All of these features provide outstanding ease of operation and further increase system reliability.



Outstanding reliability and durability

High quality, generously-sized components (e.g. in the condenser) ensure optimum flow at all times, even at high operating temperatures, and guarantee a long and dependable service life, e.g. stainless steel condensate separator*). Details such as the use of smooth-bore piping in the refrigeration circuit also contribute to exceptional system efficiency.



*) TA 5 model uses a zinc die-cast condensate separator

Equipment

General design

Tower construction with removable side panels, sheet steel panelling powder coated outside and galvanised inside; all cold components are insulated; all materials used are CFC-free; the built-in control cabinet is enclosure-protected to IP 54, air to air heat exchanger (model TA 8 upwards); condensate separating system, automatic condensate drain; scope of delivery includes refrigerant and oil.

Control panel

Equipped with dew point trend gauge, Emergency/ Off switch, LEDs to indicate "Thermal Mass Active" and "Refrigerant Compressor ON". LEDs for "High Dew Point" and "ECO DRAIN Alarm" are fitted as standard on TE models and upwards. TF models and upwards are equipped with dual operating hours counters.



Refrigerant circuit

Hermetically-sealed refrigerant circuit features large heat exchanger surface area and service valves, SECOTEC cycling control with thermal mass and automatic dew point control.



Accessories (optional)

Bypass piping system: This option ensures compressed air is supplied even while service work is carried out on the refrigeration dryer.

Technical specifications

Model *)	Flow rate in m³/min at 7 bar operating pressure **)	Differential pressure bar **)	Effective power consumption in kW **)		Power connection	Compressed air connection (Female thread)	Condensate outlet mm	Dimensions H x W x D mm	Weight kg
			At 100% rated flow capacity	At 40% rated flow capacity					
TA 5	0.60	0.07	0.25	0.11	230 V 50 Hz 1 Ph	G ¾	DN 6	779 x 484 x 630	70
TA 8	0.85	0.14	0.25	0.11					
TA 11	1.25	0.17	0.28	0.13					
TB 19	2.10	0.19	0.43	0.19					
TB 26	2.55	0.20	0.61	0.27		G 1	DN 10	963 x 540 x 620	116
TC 31	3.20	0.15	0.73	0.33					
TC 36	3.90	0.16	0.80	0.36		G 1 ¼	DN 10	1009 x 660 x 774	170
TC 44	4.70	0.15	0.90	0.41					
TD 51	5.65	0.11	0.86	0.39		G 1 ½	DN 10	1186 x 759 x 1125	251
TD 61	7.00	0.15	1.10	0.50					
TD 76	8.25	0.17	1.40	0.63					
TE 91	10.15	0.15	1.15	0.52	400 V 50 Hz 3 Ph	G 2	2x DN 10	1511 x 1060 x 1520	570
TE 121	12.70	0.18	1.45	0.65					
TE 141	14.30	0.24	1.60	0.72		DN 65	2x G ¾	1900 x 1060 x 1757	850
TF 173	17.00	0.17	2.10	0.95					
TF 203	21.00	0.16	2.20	0.99		DN 80	2x G ¾	1900 x 1060 x 1757	850
TF 251	25.00	0.19	2.50	1.13					

*) Using refrigerant R 134 a; max. operating pressure 16 bar(g); max. compressed air inlet/ambient temperature 55/43°C
 **) Performance data for reference conditions to ISO 7183, Option A: Operating pressure 7 bar(g), ambient temperature + 25°C, air inlet temperature + 35°C, pressure dew point + 3°C. The flow rate and differential pressure change for other operating conditions.

Correction factors for deviating operating conditions (flow rates in m³/min x c...)

Deviating working pressure p at dryer inlet																Compressed air inlet temperature T _i						Ambient temperature T _a								
Modell	p bar(g)	3	4	5	6	7	8	9	10	11	12	13	14	15	16	Modell	T _i (°C)	30	35	40	45	50	55	Modell	T _a (°C)	25	30	35	40	43
TA-TF	c _p	0.75	0.84	0.90	0.95	1.00	1.04	1.07	1.10	1.12	1.15	1.17	1.19	1.21	1.23	TA-TF	c _{Ti}	1.20	1.00	0.83	0.72	0.60	0.49	TA-TF	c _{Ta}	1.00	0.99	0.97	0.94	0.92

Calculation of dryer flow rate under deviating conditions:
 Example:
 Operating pressure: Air inlet 10 bar (g) > Table > c_p = 1.10
 temperature: 40°C > Table > c_{Ti} = 0.83
 Ambient temperature: 30°C > Table > c_{Ta} = 0.99

Selected refrigeration dryer: TB 19 with 2.1 m³/min (V_{Reference})
 Max. possible flow rate under operating conditions
 $V_{max, operational} = V_{Reference} \times c_p \times c_{Ti} \times c_{Ta}$
 $2.1 \text{ min}^3/\text{min} \times 1.1 \times 0.83 \times 0.99 = 1.90 \text{ m}^3/\text{min}$

Comprehensive design know-how



Typically operating at load capacities of 95 % or more, KAESER compressed air systems provide exceptional efficiency and produce application-specific quality

compressed air at lowest possible cost. Use this expertise to your advantage and let KAESER design your compressed air system.

Variant 1

For generally consistent air demand, the SECOTEC refrigeration dryer is located downstream from the air receiver.



Variant 2

For heavily fluctuating air demand, the SECOTEC dryer is located between the compressor, centrifugal separator with condensate drain and air receiver.



Installation of refrigeration dryers

Compressed air refrigeration dryers must be selected to suit actual operational conditions:

- The maximum possible flow rate through the refrigeration dryer rises with increasing working pressure.
- In contrast, the maximum possible flow rate through the dryer falls with increasing air inlet temperature.
- The maximum possible flow rate through the dryer also falls with increasing ambient temperature.

Dimensions

TA Series

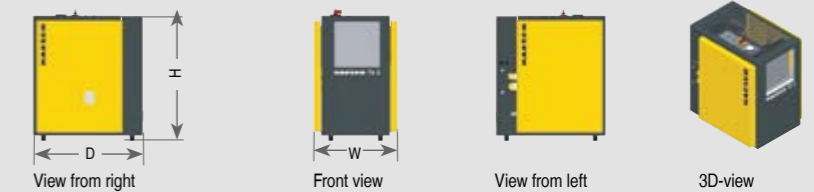

TB, TC, TD Series

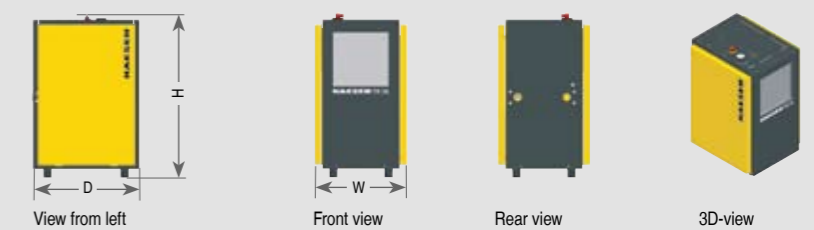

TE Series

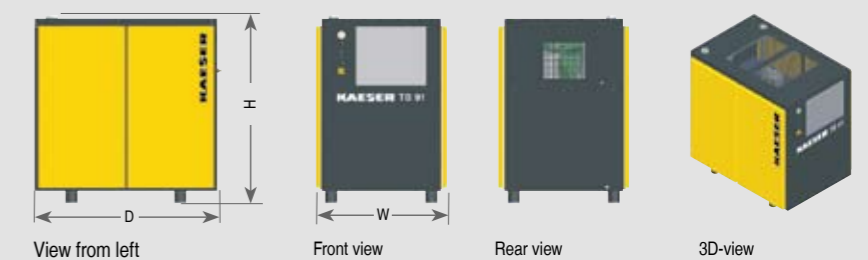

TF Series

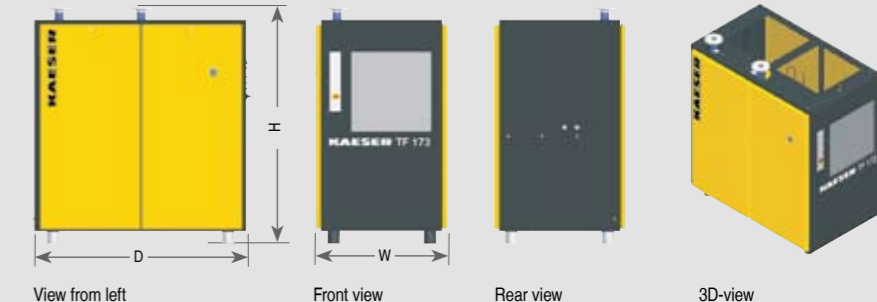

Choose the required grade of treatment according to your field of application:

Air treatment using a refrigeration dryer (pressure dew point + 3 °C)

Examples: Selection of treatment classes to ISO 8573-1¹⁾

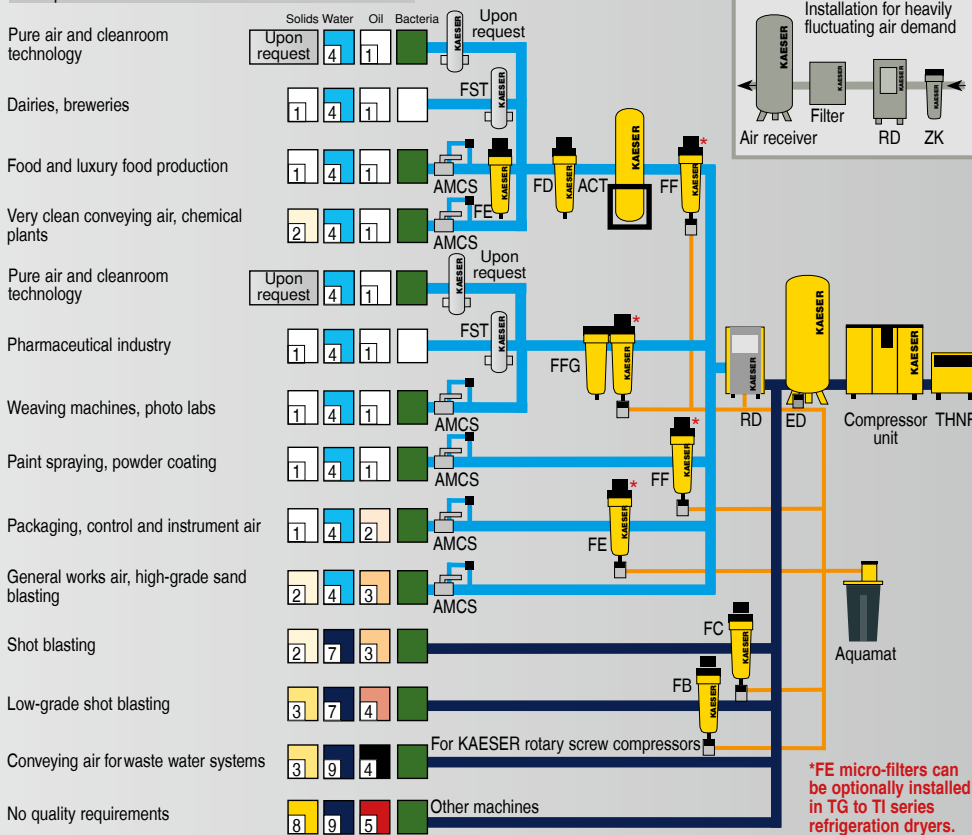

Explanation:

- THNF = Bag filter**
Cleans dusty and heavily contaminated intake air
- ZK = Centrifugal separator**
Separates accumulating condensate
- ED = Eco-drain**
Electronic level-controlled condensate drain
- FB = Pre-filter**
- FD = Particulate filter (attrition)**
- FE = Micro-filter**
Separates aerosol oil and solid particles
- FF = Micro-filter**
Separates aerosol oil and solid particles
- FG = Activated carbon filter**
For adsorption of oil vapours
- FFG = Activated carbon and micro-filter combination**
- RD = Refrigeration dryer**
For drying compressed air, pressure dew point to +3 °C
- DD = Desiccant dryer**
For drying compressed air, pressure dew point to -70 °C
- ACT = Activated carbon adsorber**
For adsorption of oil vapours
- FST = Sterile filter**
For sterile compressed air
- Aquamat = Condensate treatment system**
- AMCS = Air main charging system**

Contaminants:

+	Solids	-
+	Water/Condensate	-
+	Oil	-
+	Bacteria	-

For air mains subject to sub-zero temperatures: Compressed air treatment with a desiccant dryer (pressure dew point to -70 °C)

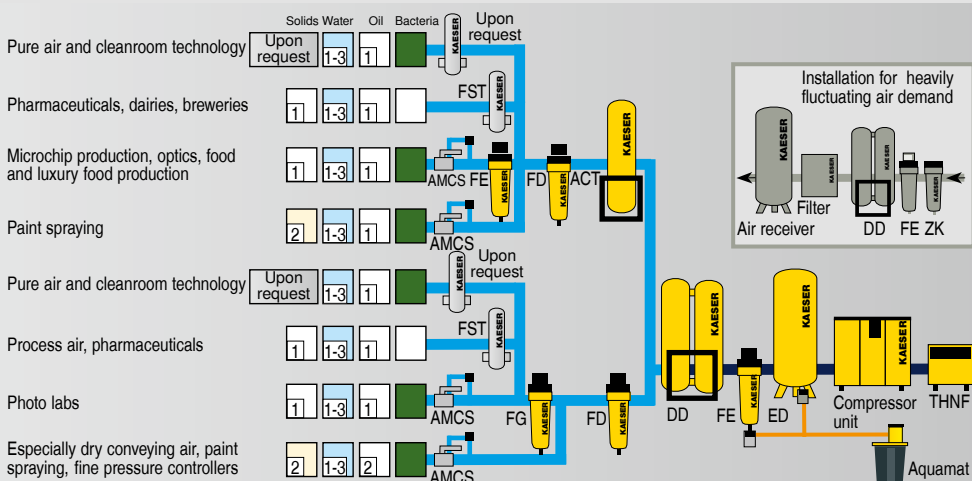

Degree of filtration:

Class ISO 8573-1	Solid particles ¹⁾		Humidity ²⁾	Total oil content ²⁾
	Max. particle size µm	Max. particle concentration mg/m ³	Pressure dew point (x = Liquid water in g/m ³)	mg/m ³
0	e.g. Consult KAESER regarding pure air and cleanroom technology			
1	0.1	0.1	≤ -70	≤ 0.01
2	1	1	≤ -40	≤ 0.1
3	5	5	≤ -20	≤ 1
4	15	8	≤ +3	≤ 5
5	40	10	≤ +7	-
6	-	-	≤ +10	-
7	-	-	x ≤ 0.5	-
8	-	-	0.5 < x ≤ 5	-
9	-	-	5 < x ≤ 10	-

¹⁾ As per ISO 8573-1:1991 (The specification for particle content is not measured as per ISO 8573-1:2001, as the limits defined therein for Class 1 are to be applied to 'Cleanrooms').
²⁾ As per ISO 8573-1:2001

KAESER Compressors SA (PTY) Ltd.

79 Watt Street – 1401 Meadowdale-Johannesburg – P.O. Box 5031
Phone: 0027 11974 5002 – Fax: 0027 11974 6696
www.kaeser.co.za – Email: info.southafrica@kaeser.com



KAESER Kompressoren GmbH

P.O. Box 2143 – 96410 Coburg – GERMANY – Tel: +49 9561 640-0 – Fax: +49 9561 640130
www.kaeser.com – e-mail: productinfo@kaeser.com